



D'Vine Intervention

Every Drop Counts

OPERATING MANUAL – SWEETSPOTTER SS4-1-10

Dated: August 31st, 2012

Revision: 4

TECHNICAL SPECIFICATIONS

Model	: SS4-1-10
Permeate flow rate	: 10 gallons per hour
Wine flow rate	: 130 gallons per hour
Maximum operating pressure	: 850 psi
Power requirement	: 110V 1 Phase power
Maximum cleaning fluid temp	: 120°F (through cleaning ports only)
Recommended cleaning chemical	: TSP – Non Chlorinated

IMPORTANT TO REMEMBER

- Do not use chlorine in any form!
- Do not use Proxycarb for cleaning purposes.
- Do not close a valve on the inlet to the machine without turning off the feed pump first! This will cause the feed pump to cavitate and can lead to damage.
- Check pre-filter regularly for debris build-up and clean regularly.
- Very cold wine (< 55F) will increase the required operating pressure of the system and or decrease the permeate flow rate to unacceptable levels.
- Do not soak the membranes in a solution greater than a pH of 11.

WARNING

Please do not place the handles on the plastic 3-way valves at a 90 degree angle while the System pump is switched on and the intensifier is pressurized. This will cause lines to burst or the feed pump to fail prematurely! The System can generate pressures of up to 1300 psi if blocked completely, resulting in catastrophic failure of hoses and loss of product!



RESPONSIBILITY

Please note that neither D'Vine Intervention nor VA Filtration will accept responsibility for damage or loss of wine resulting from the operation of the Sweetspotter equipment. We would recommend that you familiarize yourself completely with the operation of the machinery by reading these instructions carefully prior to wine processing and make sure you supervise the machinery at all times.

If you are unsure about the operation of the equipment, please refer to the operating manual or contact one of our staff members and we would be happy to help you. It is critical that the operating manual is read thoroughly before using this equipment. If you do not feel comfortable operating the machine we can supply an operator to set up the system at a rate of \$90.00 per hour plus travel.



Background on the System

The SS4-1-10, hereinafter called the SYSTEM, has been designed for the processing of smaller lots of wine for the removal of VA, 4EP, taints and cold stabilization. The system uses cutting edge technology to generate the necessary pressure required to produce permeate for VA removal without the requirement of a high pressure-pumping device. This means that the wine is handled as gently as possible.

Process flow rates from the system depend a great deal on the wine temperature and turbidity. The cleaner the wine, the longer the system is going to deliver a constant flow rate. Should the wine be dirty, then the system will require more frequent cleaning. If lees are pulled into the system, this may irreversibly foul the membranes requiring complete membrane replacement.

The system is supplied with quick disconnect open hose ends or 1.5" triclamp inlet, outlet and permeate connections.

What you need before you start

- Cold pressurized water (preferably dechlorinated).
- 2 x 5 gallon buckets
- 110 Volt 1 phase power supply nearby.
- A handheld pH meter or accurate lab based pH meter
- Wine to be processed in barrel/tank at 55°F or higher.
- TSP and citric acid

Please note that there are two or four connections to the System depending on your configuration. These are as follows:

Cartridge configuration

- Wine Inlet – quick disconnect
- Wine Outlet – quick disconnect

Column configuration

- Wine Inlet – quick disconnect
- Wine Outlet – quick disconnect
- Permeate Outlet (3/8" tubing with 1.5" tri-clamp on the end)
- Permeate Return (3/8" tubing with 1.5" tri-clamp on the end)



FRONT ISOMETRIC VIEW

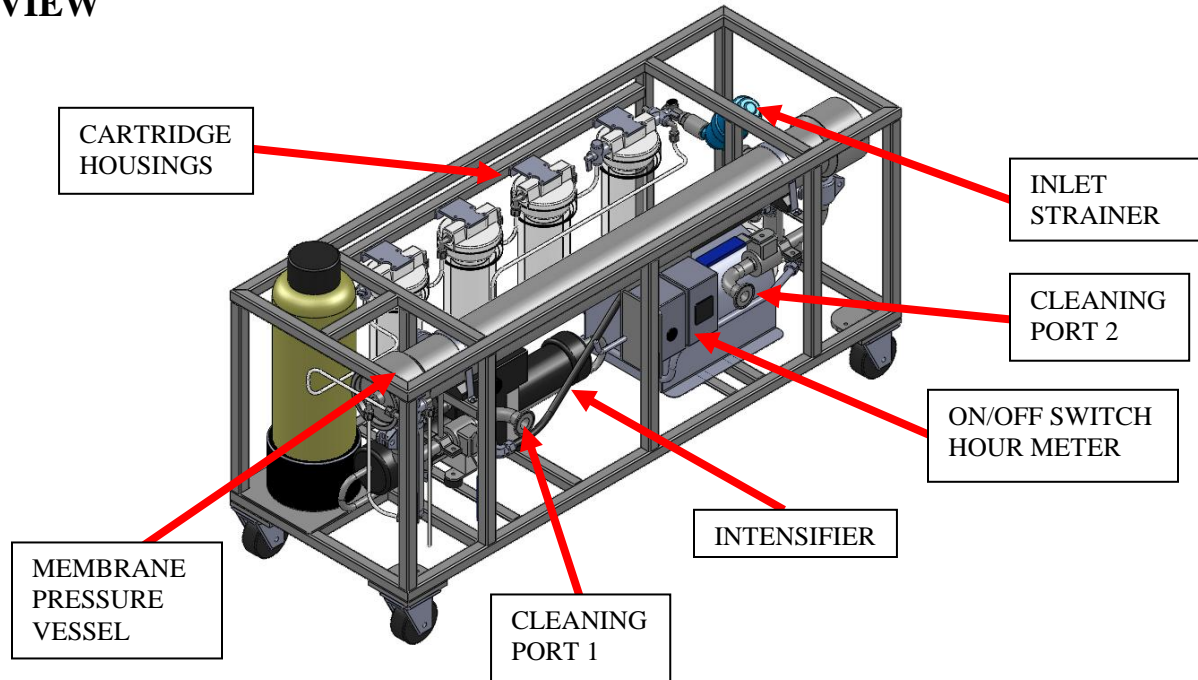

RIGHT SIDE VIEW

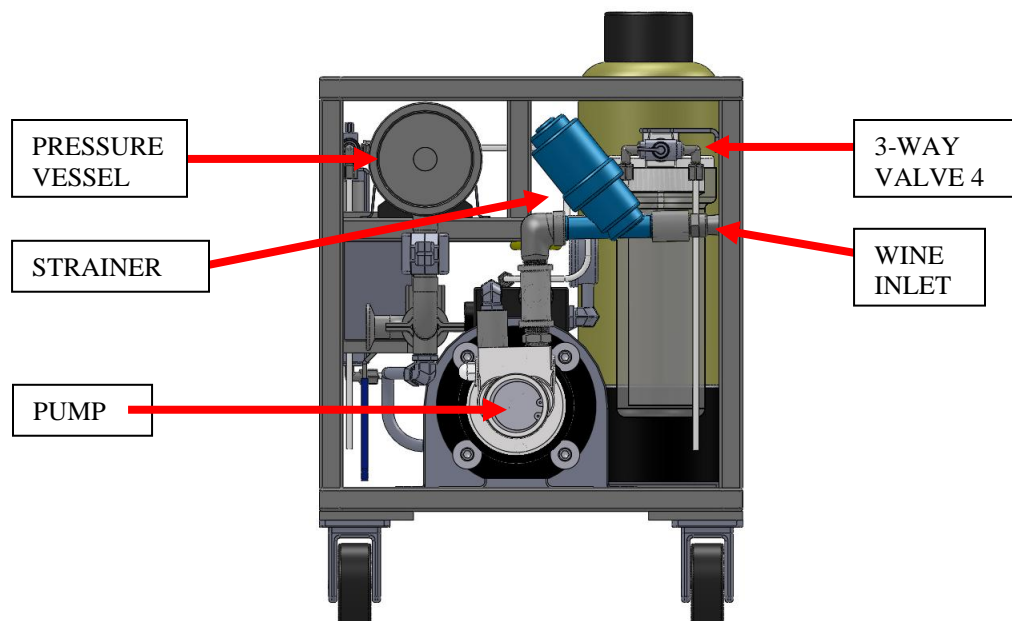



FRONT VIEW

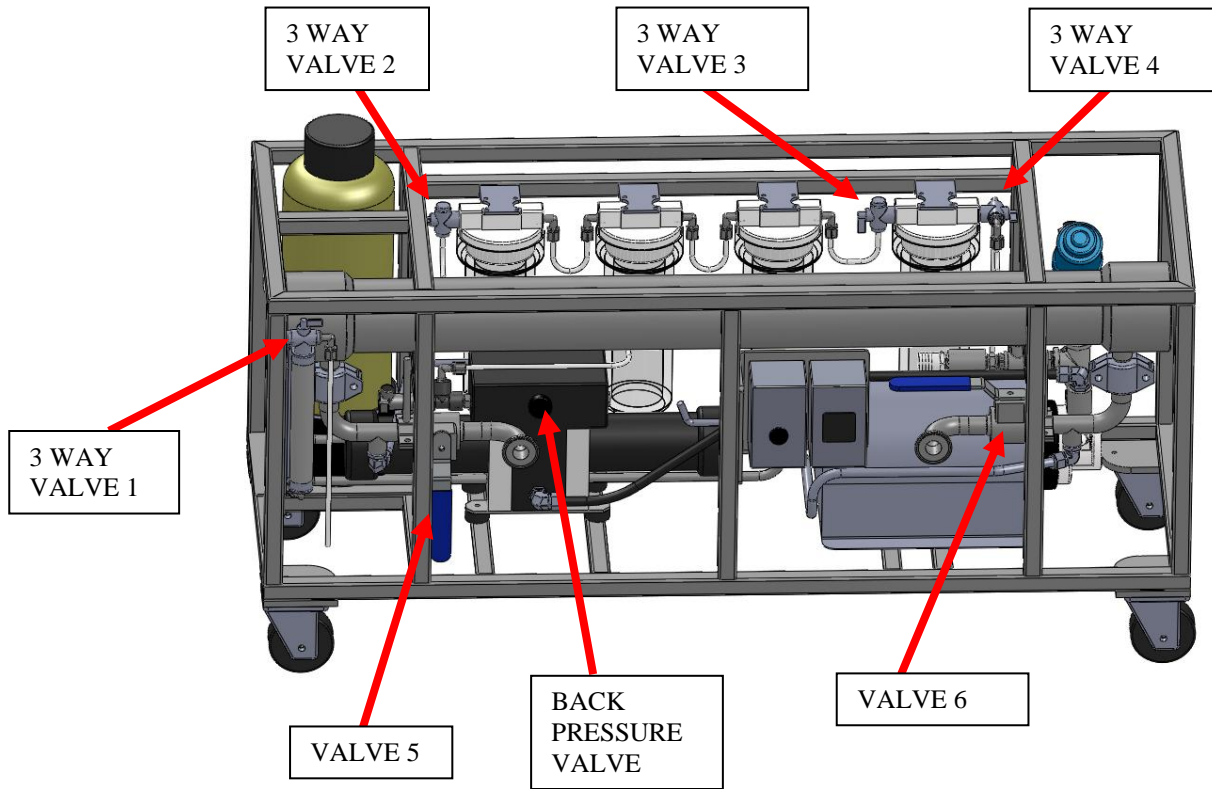

LEFT SIDE VIEW

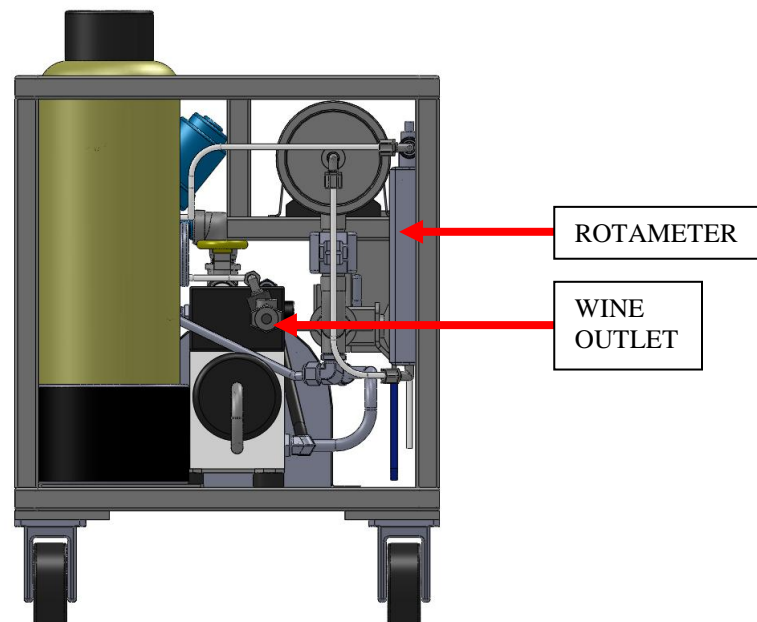



GETTING STARTED

PLEASE READ INSTRUCTION THOROUGHLY BEFORE USE. WE ARE NOT RESPONSIBLE FOR LOSS OF PRODUCT DUE TO NEGLIGENCE OR FAILURE TO FOLLOW INSTRUCTIONS.

ELECTRICAL

- Connect the power cable to a 110V outlet.
- Do not turn on the pump yet.

HOSE CONNECTIONS (see drawings above for correct fitting location)

N.B. Please check o'rings on the plastic fitting end of the hoses. If they are dry, lubricate with water or food grade grease to avoid damage when connecting to the machine.

- Insert the fitting end of hose 1 of 2 provided into the WINE INLET quick disconnect.
- Insert the fitting end of Hose 2 of 2 provided into the WINE OUTLET quick disconnect.

Water Rinse- CRITICAL

- The machinery is supplied with a citric acid solution. This needs to be rinsed before processing wine.
- Fill a 5 gallon bucket with cold water.
- Place the end of the WINE INLET HOSE into the bucket containing the water.
- Place the end of the WINE OUTLET HOSE into another empty bucket.
- Turn Valve 1 handle so that it points to the left – to open ended tube.
- Open the BACK PRESSURE VALVE on the INTENSIFIER – 2 turns to the left.
- Switch on the pump by turning the electrical switch to the right.
- Rinse for 5 minutes.
- Close the PRESSURE VALVE on the INTENSIFIER for 2 minutes to ensure complete water rinsing. Open again and let run.



Citric acid rinsing

It is good practice to rinse the system with a citric acid solution prior to using it to treat wine. This does not have to take place between lot changes but should take place after each clean and prior to each run after the system has been left with a cleaning solution inside.

- Mix up approximately 5 gallons of a 1% citric acid solution in a container or tank (0.5 lb citric in 5 gallons)
- Place the end of the WINE INLET hose into the bucket containing the citric acid solution.
- Place the WINE OUTLET hose into another empty bucket.
- Turn Valve 1 handle so that it points to the left.
- Open the BACK PRESSURE VALVE on the INTENSIFIER – 2 turns to the left.
- Switch on the pump by turning the switch to the right.
- Rinse for 5 minutes.
- Close the PRESSURE VALVE on the INTENSIFIER for 2 minutes to ensure complete water rinsing. Open again and let run.

If the system does not suck up the citric acid solution, check that the PRESSURE VALVE on the INTENSIFIER is open.

Water Rinse prior to Wine Processing

Once the Citric acid wash is complete. Follow up with a water rinse again until all the citric acid is gone.

- Fill a 5 gallon bucket with cold water.
- Place the end of the WINE INLET hose into the bucket containing the water.
- Place the WINE OUTLET hose into another empty bucket.
- Turn Valve 1 handle so that it points to the left.
- Open the BACK PRESSURE VALVE on the INTENSIFIER – 2 turns to the left.
- Switch on the pump by turning the switch to the right.
- Rinse for 5 minutes.
- Close the PRESSURE VALVE on the INTENSIFIER for 2 minutes to ensure complete water rinsing. Open again and let run until water exiting the wine outlet hose is free of taste.



Proceed to either the cartridge section or the Column section for the correct second stage treatment configuration.

Wine Processing – Cartridges Only

Please ensure that your wine for processing is as clean as possible. The cleaner the wine, the longer the membrane elements will last.

Cartridge Arrangement

Cartridges available

VA – Resin for acetic acid reduction only.

HpH – High pH resin for acetic acid and ethyl acetate reduction

pHC – pH Correction resin for stabilizing wine pH during VA reduction or for adjusting pH LOWER. Can also be used in VA reduction to keep pH constant. Also used for cold stabilization of wine.

VA Reduction

Place 1 x pHC cartridge in housing 1 and 3 x VA cartridges in housings 2, 3 and 4.

Combination VA/Ethyl acetate reduction

3 x HpH cartridges in housings 1, 2 and 3, and 1 x pHC cartridge in housing 4

pH Correction

4 x pHC Cartridges in housings 1, 2, 3 and 4

Taint Reduction including 4EP, DES, Smoke, Eucalyptol etc

4 x Carbon cartridges in Housings 1, 2, 3 and 4

Step 1 - Start-Up

- Place the end of your WINE INLET hose into the barrel or connect to the tank to be treated.
- Leave the end of the WINE OUTLET hose in an empty 5 gallon bucket.
- Insert the necessary cartridge filters into the CARTRIDGE HOUSINGS by unscrewing the filter bowl, placing the cartridges into the bowl (black seal side up) and screwing the bowl back into place.
- Check that the valves are orientated as follows when standing at the front of the machine:
 - a. VALVE 1 – Handle pointing to the left.
 - b. VALVE 2 – Handle pointing right.
 - c. VALVE 3 – Handle pointing to the electrical box or Front of the machine.
 - d. VALVE 4 – Handle pointing toward the back of the machine.
- Switch on the system pump (switch on the front of the machine).
- Watch for wine exiting the WINE OUTLET HOSE – 10 seconds or so.



- Taste the liquid exiting the WINE OUTLET HOSE and as soon as wine is tasted, switch off the pump.
- Place the end of the WINE OUTLET HOSE into the barrel being treated or connect to the tank.
- Switch on the pump again.

Step 2 - Pressurizing the System

- With wine flowing, close the BACK PRESSURE VALVE on the intensifier (turn to the right) – THUMB TIGHT.
- Watch the pressure increase slowly and watch for flow in the FLOW METER.
- The system will be pulsing as pressure builds up.
- Liquid should be seen exiting Valve 1 after about 30 seconds.
- The ROTAMETER float will be rising and falling as the system stabilizes.
- **Taste the liquid exiting Valve 1 for alcohol and then turn VALVE 1 to the right.**

Step 3 - Treating the Permeate

- The CARTRIDGE Housings should now be filling with liquid. If you see any fittings spraying liquid at this time, shut off the machine immediately and check for tightness and restart.
- Bleed the cartridge housings by pressing the red bleeder valve located on top of the housing.
- After the Housings fill the liquid will exit out the back of Valve 4.
- Taste the liquid exiting VALVE 4 for alcohol. When alcohol is tasted rotate the valve 180 degrees so that the handle is facing toward the front of the machine. NEVER leave the valve in the 90° position – cartridge housings will burst.
- If running Brett removal, the permeate stream exiting Valve 4 may have a grey tint to it. Please do not worry; this will clear up within 30 seconds to a minute.

Checks to be carried out during operation

If only running VA Reduction

- Measure the pH of the **permeate** exiting Valve 4 on a regular basis (every 30 minutes) to gauge when the cartridges require replacing. The pH range should be between 7 and 10.5.
- When the pH of the permeate exiting Valve 4 drops below 7, open the BACK PRESSURE VALVE and switch off the machine.
- Remove the cartridges from the housings. Empty the residual permeate into the barrel or tank and place a fresh set of cartridges into the housings.



- Once all the cartridges are replaced, turn the handle of Valve 4 so that the end points to the electrical box. Follow the start-up instructions as above.

Your system is now removing VA and can be left to run for as many hours as is necessary to reduce the VA to your target level.

Acetic Acid Reduction (1 X pHC and 3 x VA Cartridges)

- Measure the pH of the **permeate** exiting Valve 4 on a regular basis to gauge when the cartridges require replacing. To get a sample from Valve 4, rotate the handle 180° until liquid flows from the sample tubing. The pH should be between 7 and 10.
- When the pH of the permeate exiting Valve 4 drops below 7, open the BACK PRESSURE VALVE and switch off the machine.
- Remove the 3 VA cartridges from the housings. Empty the residual permeate into the barrel or tank and place a fresh set of cartridges into the housings.
- Start the machine again, taste out at Valve 4 and resume processing.
- WHEN the next set of VA cartridges require replacing, remove the pHC cartridge from housing number 1 and replace with a fresh cartridge. ONLY REPLACE 1 PHC FOR EVERY 2 SETS OF VA CARTRIDGES USED.
- Start the machine again, taste out at Valve 4 and resume processing.

Ethyl Acetate Reduction (3 x HpH and 1 x pHC Cartridge)

- Measure the pH of the **permeate** exiting Valve 3 on a regular basis to gauge when the HpH cartridges require replacing. To get a sample from Valve 3, unscrew the tubing going into the valve, take a sample and then screw back in ensuring no leaks. Do not turn the valve handle, this will block flow from the machine permeate and burst a housing. The pH should be between 7 and 12.5. This stream might smell like caustic or soap – this is normal.
- When the pH of the permeate exiting Valve 3 drops below 7, open the BACK PRESSURE VALVE and switch off the machine.
- Remove the cartridges from the housings. Empty the residual permeate into the barrel or tank and place a fresh set of cartridges into the housings.
- Start the machine again, taste out at the entrance to Valve 3 and resume processing.
- Measure the pH of the permeate exiting Valve 4 on a regular basis to gauge when the pHC cartridge requires replacement. The pH should be between 2 and 4.5.
- When the pH of the permeate exiting Valve 4 increases above 4.5, open the BACK PRESSURE VALVE and switch off the machine.



- Remove the cartridge from the housing. Empty the residual permeate into the barrel and place a fresh cartridge into the housing.
- Start the machine again, taste out at Valve 4 and resume processing.
- Once all the cartridges are replaced, turn the handle of Valve 4 so that the end points to the electrical box. Follow the start-up instructions as above.

If running pH Correction or Cold Stabilization

- Measure the pH of the **permeate** exiting Valve 4 on a regular basis to gauge when the cartridges require replacing. The pH range should be between 2 and 4.5.
- When the pH of the permeate exiting Valve 4 increase to above 4.5, open the BACK PRESSURE VALVE and switch off the machine.
- Remove the cartridges from the housings. Empty the residual permeate into the wine being treated and place a fresh set of cartridges into the housings.
- Once all the cartridges are replaced, turn the handle of Valve 4 so that the end points to the electrical box. Follow the start-up instructions as above.

If running for taint removal

- Take a sample of the permeate before the cartridges and place it in a glass. You collect the sample by turning Valve 1 to the left and collecting the liquid exiting the tube.
- Take a second sample from Valve 4 by turning the valve handle towards the back of the machine and collecting the liquid exiting the line. Add this liquid to a second glass.
- Compare the aroma before and after on the 2 permeate samples. There should be a distinct difference. If they are the same, then the carbon cartridges require replacing.



Wine Processing – Resin Columns or Carbon Columns

Please ensure that your wine for processing is as clean as possible. The cleaner the wine, the longer the membrane elements will last.

N.B. - Prior to using any of the columns

- **The VA Column needs to be rinsed until the water exiting the column has reached a pH of 10.5.**
- **The HpH column needs to be rinsed for 15 minutes.**
- **The pHC column needs to be rinsed for 15 minutes.**
- **The Brett column needs to be rinsed for 15 minutes.**

Always make sure the columns are full by opening the bleeder valves on top during rinsing.

Once the rinse has been completed, please purge with nitrogen making sure all the liquid is out of the columns before using them on wine.

Column Arrangement

Columns available

HpH – High pH resin for acetic acid and ethyl acetate reduction

pHC – pH Correction resin for stabilizing wine pH during VA reduction or for adjusting pH down. Also used for cold stabilization of wine.

Carbon – Taint reduction

Column Configurations

VA Reduction

1 x pHC Column followed by a VA resin column

Combination VA/Ethyl acetate reduction

1 x HpH Resin column followed by pHC column

pH Correction

1 x pHC Column

Taint Reduction including 4EP, DES, Smoke, Eucalyptol etc

1 x Carbon column



Step 1 - Start-Up

- Place the end of your WINE INLET hose into the barrel or connect to the tank to be treated.
- Leave the end of the WINE OUTLET hose in an empty 5 gallon bucket.
- Check that the valves are orientated as follows when standing at the front of the machine:
 - a. VALVE 1 – Handle pointing to the left.
 - b. VALVE 2 – Handle pointing to the left.
 - c. VALVE 3 – Handle pointing to the back of the machine.
 - d. VALVE 4 – Handle pointing toward the back of the machine.
- Switch on the system pump (switch on the front of the machine).
- Watch for wine exiting the WINE OUTLET HOSE – 10 seconds or so.
- Taste the liquid exiting the WINE OUTLET HOSE and as soon as wine is tasted, switch off the pump.
- Place the end of the WINE OUTLET HOSE into the barrel being treated or connect to the tank.
- Now connect the resin columns.

Step 2 – Column Connection

If Running Acetic Acid Reduction

- Connect the 3/8” tube line from Valve 2 on the machine to the INLET of Column 1 which should be the pHc column. Connect the jumper house supplied between the OUTLET of Column 1 (pHc) and INLET of Column 2 (VA Column). Connect the second 3/8” tube line from the OUTLET of Column 2 to Valve 3 on the machine.
- Make sure Valve 1 handle points toward the left.
- Make sure Valve 2 handle points toward the left.
- Make sure Valve 3 handle points toward the back of the machine.
- Make sure Valve 4 handle points toward the back of the machine.
- Check that the bleeder valves on top of the columns are closed.

If Running Ethyl Acetate

- Connect the 3/8” tube line from Valve 2 on the machine to the INLET of Column 1 which should be the VA or HpH column. If using a second columns connect the jumper house supplied between the OUTLET of Column 1 (VA or HpH) and INLET of Column 2 (pHc). Connect the second 3/8” tube line from the OUTLET of Column 2 to Valve 3 on the machine.



- Make sure Valve 1 handle points toward the left.
- Make sure Valve 2 handle points toward the left.
- Make sure Valve 3 handle points toward the back of the machine.
- Make sure Valve 4 handle points toward the back of the machine.
- Check that the bleeder valves on top of the columns are closed.

If Running pH Correction, Cold Stabilization or Taint reduction

- Typically only one column for each process is used. Connect the 3/8" lines to the INLET and OUTLET of the correctly selected columns.
- Make sure Valve 1 handle points toward the left.
- Make sure Valve 2 handle points toward the left.
- Make sure Valve 3 handle points toward the back of the machine.
- Make sure Valve 4 handle points toward the back of the machine.
- Check that the bleeder valves on top of the columns are closed.

Step 3 - Pressurizing the System

- Switch on the system pump.
- With wine flowing, close the PRESSURE VALVE on the intensifier (turn to the right) – THUMB TIGHT.
- Watch the pressure increase slowly and watch for flow in the FLOW METER.
- The system will be pulsing as pressure builds up.
- Liquid should be seen exiting Valve 1 after about 30 seconds.
- The ROTAMETER float will be rising and falling as the system stabilizes.
- **Taste the liquid exiting Valve 1 for alcohol and then turn VALVE 1 to the right.**

Step 4 – Filling the Columns

- The COLUMNS should now be filling with liquid. This is a slow process and depending how many columns are in line and the size of the columns, could take up to 20 minutes for liquid to finally exit at Valve 4. Cartridge Housing 4 will start filling prior to liquid exiting Valve 4.
- While the system is in operation, check for leaking fittings. If anything is seen leaking, open the BACK PRESSURE VALVE and switch off the machine. Tighten the fittings and re-start the system.
- When liquid finally starts flowing from Valve 4, it will contain 100% water. This stream needs to be checked continuously until alcohol can be tasted.
- When strong alcohol is tasted exiting Valve 4, open the bleeder valves on top of the resin columns. Gas will be heard escaping. Leave the bleeder valves open until liquid is seen exiting these valves, then close each one only when liquid is seen. Repeat for each column.



- When the final bleeder valve is closed, turn the handle on Valve 4 180° so that it is pointing toward the front of the machine.
- If running Brett removal, the permeate stream exiting Valve 4 may have a grey tint to it. Please do not worry; this will clear up within 5 minutes.

Your system is now in process mode and can be left to run for as many hours as is necessary to reduce the VA to your target level. It is important though to check the permeate streams frequently to ensure the system is working efficiently.

Checks to be carried out during column operation

VA Reduction

- There are several places to monitor the permeate pH during treatment. The bleeder valve on top of Column 1 will give you the pH of the permeate exiting the membranes. The bleeder valve **on top of** Column 2 will give you the pH of the permeate exiting Column 1. The liquid exiting Valve 4 will be the pH of the permeate exiting Column 2.
- Measure the pH of the **permeate** exiting the Bleeder Valve on Column 2 on a regular basis (every 30 minutes). The pH range should be between 2.5 and 3.5.
- When the pH of the permeate exiting the Bleeder valve on Column 2 rises above 3.5, this means Column 1 is saturated and requires replacing or regeneration. Refer to *pH Correction Column Saturated* below for detailed instructions on removal of the spent column.
- Measure the pH of the permeate exiting Valve 4 on the machine also every 30 minutes. It should be between 6 and 10.5.
- When the pH of the permeate exiting Valve 4 drops below 6, the column is saturated and requires replacing or regeneration. Please refer to *VA Resin Column Saturated* for detailed instructions on removal of the spent column.

Ethyl Acetate

- There are several places to monitor the permeate pH during treatment. The bleeder valve on top of Column 1 will give you the pH of the permeate exiting the membranes. The bleeder valve **on top of** Column 2 will give you the pH of the permeate exiting Column 1. The liquid exiting Valve 4 will be the pH of the permeate exiting Column 2.
- Measure the pH of the **permeate** exiting the Bleeder Valve on Column 2 on a regular basis (every 30 minutes). The pH range should be between 7 and 10.



- When the pH of the permeate exiting the Bleeder valve on Column 2 drops below 7, this means Column 1 is saturated and requires replacing or regeneration. Refer to *HpH Column Saturated* below for detailed instructions on removal of the spent column.
- Measure the pH of the permeate exiting Valve 4 on the machine also every 30 minutes. It should be between 2 and 4.5.
- When the pH of the permeate exiting Valve 4 rises above 4.5, the column is saturated and requires replacing or regeneration. Please refer to *pH Correction Column Saturated* for detailed instructions on removal of the spent column.

HpH or VA Column Saturated

- Open the BACK PRESSURE VALVE on the machine and switch off the machine.
- Wait 2 minutes.
- Disconnect the line from the INLET of Column 1 (HpH Column).
- Connect a nitrogen line to the INLET of Column 1.
- Set the nitrogen at 20 psi and purge until nitrogen bubbles are seen flowing into Column 2.
- Turn off the nitrogen and wait 2 minutes.
- Open the bleeder on top of column 1.
- Disconnect the INLET and the OUTLET lines from Column 1.
- Replace with a new rinsed and purged column or refer to regeneration instructions for HpH resin columns.
- Connect the fresh column in the line by referring to the *Column Connection* instructions above and repeat all subsequent steps until you are up and running.

pH Correction Column Saturated

- Open the BACK PRESSURE VALVE on the machine and switch off the machine.
- Wait 2 minutes.
- Disconnect the hose from the INLET of Column 2 (pH Correction column).
- Connect a nitrogen line to the INLET of Column 2.
- Set the nitrogen at 20 psi and purge until nitrogen bubbles are seen flowing into Cartridge housing 4.
- Turn off the nitrogen and wait 2 minutes.
- Open the bleeder on top of column 2.
- Disconnect the INLET and the OUTLET lines from Column 2.
- Replace with a new rinsed and purged column or refer to regeneration instructions for pH Correction columns.



- Connect the fresh column in the line by referring to the *Column Connection* instructions above and repeat all subsequent steps until you are up and running.

If running pH Correction or Cold Stabilization only

- Measure the pH of the **permeate** exiting Valve 4 on a regular basis to gauge when the columns require replacing. The pH range should be between 2 and 4.5.
- When the pH of the permeate exiting Valve 4 increase to above 4.5, refer to the *pH Correction Column Saturated* instructions above.

If running Taint Removal only

- Take a sample of the permeate before (Valve 1) and after the carbon column (Valve 4).
- Place the sample in a glass and compare the before and after aromas. If there is a big difference, the column is working. If they are similar, the column is saturated.

Storing of resin columns at the end of the day or at the end of a run

- Resin columns can be left full of permeate over night for processing the next day.
- If they are not going to be used within the next 48 hours, they should be purged of permeate and rinsed with water. They should be left full of water.
- If not going to be used for a week, they need to be regenerated and left full of water.

SYSTEM CHECKS – All Processes

Once the system is running, please check the following for correct operation:

- Permeate is flowing at 10 gal/hr or 0.16-0.18 gal/min.
- The System is pulsing. If no pulsing is taking place, check troubleshooting.
- The permeate is clear (it might have a pink tinge in the beginning, but this should clear up).

We would recommend recording the start-up pressure and flows as a function of time on a log sheet. Re-check every half hour and record the latest values on the log sheet. Please record time (from hour run meter), permeate flow rate,



operating pressure, permeate pH exiting column 1, permeate pH exiting column 2 and time when columns were replaced or regenerated.

- **PLEASE CHECK THE SYSTEM EVERY 30-60 MINUTES OR MORE FREQUENTLY AS IS DEEMED NECESSARY.**
- **CHECK pH FREQUENTLY TO ENSURE ADEQUATE REMOVAL OF ACETIC ACID**
- **WHEN RUNNING 4EP REDUCTION, CHECK PERMEATE AROMA EXITING FINAL CARTRIDGE TO TELL IF BRETT CARTRIDGES ARE STILL REMOVING 4EP AND 4EG.**

PRESSURE ABOVE 800 PSI

If at any time the pressure of the system exceeds 800 psi, the membranes are fouled and the system needs cleaning. If the system reaches 800 psi within minutes of starting up after a clean, then the RS of the wine is too high for the temperature. Check with the office if it is appropriate to run at these conditions.

FLOWRATE AND NECESSARY RUN TIME

Your system is equipped with a rotameter (Flow Meter). Your system permeate flow rate should be 10-12 gal/hr.

Please read the flow rate at the top of the float for accuracy. Note that for a 30% reduction in the VA, approximately 50% of the volume of wine as permeate needs to pass through the resin vessels. This is the same for 4EP/4EG reduction. For instance, a 600 gallon tank would require 300 gallons as permeate to be passed through the treatment column in order to achieve a 30% reduction in the VA or 4EP level. This equates to a run time of approximately 30 hours.

Here are approximate volumes to be processed based on percentage drops of VA and/or 4EP:

20% VA or 4EP Reduction	: Treat 40% of the volume as permeate
30% VA or 4EP Reduction	: Treat 50% of the volume as permeate
40% VA or 4EP Reduction	: Treat 60% of the volume as permeate
50% VA or 4EP Reduction	: Treat 70% of the volume as permeate



IMPORTANT

If you run this system on clean, filtered or well-racked wine, you will have a longer life expectancy from the membranes.

Please check the inlet screen daily to ensure it is clean. It can be pressure washed.

END OF RUN

Once finished with the wine, you can either go onto another wine or clean the system with water. As long as the system is not dirty, it can be used to process another tank or cleaned as necessary.

- Open the PRESSURE VALVE on the INTENSIFIER.
- Wait 1 minute.
- Switch off the pump.
- Remove the WINE INLET HOSE from the feed tank/barrel.
- Remove the cartridges from the housings and pour the residual permeate back into the barrel or purge out the columns with nitrogen.
- Rotate Valve 1 handle to the right.
- Fill a 5 gallon bucket with water.
- Place the end of the WINE INLET hose in the bucket of water.
- Leave the WINE OUTLET HOSE in the barrel that you have been processing.
- Switch on the pump.
- Taste out the wine returning to the barrel. Once water is tasted, remove the hose from the barrel and leave to run freely to drain.
- Leave the machine flushing for 1-2 minutes. Keep water flowing to the bucket to avoid running out of water while flushing.

Warm Water Flushing – Using the machine pump

- Warm water can now be used for flushing if required. This will aid in the removal of colloids from the membranes. Please do not exceed 120°F on the water flush.
- Close the PRESSURE VALVE every 5 minutes for 2 minutes to flush through the permeate line too.



CLEANING INSTRUCTIONS FOR SYSTEM

Once you have completed the filtration of the wine, please follow the cleaning instructions to ensure that the wine is cleaned out of the system prior to storage.

WATER RINSE 1 – Using Machine Pump

- Warm water can now be used for flushing if required. This will aid in the removal of colloids from the membranes. Please do not exceed 120°F on the water flush.
- Close the Pressure Valve on the Intensifier every 5 minutes for 2 minutes to flush through the permeate line too.
- Rinse system for 5 to 10 minutes to ensure removal of most of the color.

Non Chlorinated TSP Wash 1 (or Caustic potash if available) – Using a winery pump

The ideal cleaning solution is TSP in 120F water.

Please use a winery pump with a variable speed flow rate and connect it using 1” or 1.5” winery hose to Cleaning port 1. Connect another open ended 1” or 1.5” winery hose to Cleaning Port 2.

1. Open Valve 5 and Valve 6. Close the Pressure Valve on the intensifier.
2. Open the STRAINER and remove the cartridge. Rinse debris under running water and return to the housing.
3. Mix up a 1% solution (i.e. 1 kg of TSP in 100 liters (25 gallons) of water) in 25 gallons of 120°F water.
4. Pump this solution through the Membranes using your winery pump to drain. You should have at least 8-10 gpm of flow.
5. When you first run the cleaning solution through the membranes, the solution exiting the membranes will be purple and will turn to orange slowly over time. Once all 25 gallons has been pumped through the system, mix another 1% solution and this time recirculate to the same tank for 10 minutes.

Check the screen in the STRAINER again after your TSP clean. If dirty, rinse out and put back.



WATER WASH 2 – Using Winery Pump

Once the TSP wash has been completed, rinse the system again with warm water.

CITRIC WASH 1 – Using Winery Pump

Mix up a 1% solution (i.e. 1 kg of Citric acid in 100 liters (25 gallons) of water). Pump this solution through the Membranes using your winery pump to drain. When you first run the cleaning solution through the membranes, the solution exiting the membranes should be clear. If it is pink. Repeat the TSP cleaning procedure again after you have rinsed out the citric acid

Please note that citric acid is used as a neutralizing agent as well as to convert tannins that have not been removed from the membrane elements into tannic acid. Soaking the membrane elements in Citric Acid converts the tannin into tannic acid. If you follow this with a warm water rinse, and a TSP wash, these tannins eventually get removed.

END OF CLEAN

Once the citric acid is run clear, add a little KMBS to the citric solution, recirculate through the membranes, switch off the recirc pump and Close valves 6 and 7. You can leave the system in this state for up to a month after which we would recommend cleaning of the system again to prevent mold and or bacteria growth.

EXTENDED SOAK.

If the system has been used for a long period of time or is not delivering a sufficient volume of permeate, it may be necessary to soak the system over night in TSP. To do this carry out the cleaning procedure as above, but stop after the first TSP clean. Check the pH of the solution recirculation through the membranes and make sure it is between 11 and 12. If it is too high, adjust the pH slightly with some citric acid.

LONG TERM STORAGE

Recirculate a KMBS solution (0.2%) through the membrane elements using the cleaning ports only. When complete, close all valves and store machine. Please remove filter bowls and rinse storing externally from the machine. Replace the solution every 2 weeks.



TROUBLESHOOTING

The system does not deliver any permeate after cleaning or during start-up.

Cause

- This may be caused by a blockage in the filter screen located in the STRAINER.
- Another cause could be that the back pressure valve has not been closed.

Solution

- Check the Pressure Valve on the intensifier is closed! If it is, proceed to the next step.
- Switch off the pump and close all valves from the wine tank. Remove the Inlet Filter housing by unscrewing to the left. Once loose, the filter cartridge inside can be inspected for debris or blockage. Clean with hot water if necessary.
- If this fails to solve the problem, switch off the system and carry out a full chemical clean.
- If this still fails to solve the problem, then call our service department to schedule a service on the machine.

The System only delivers 6 gal/hr of permeate flow

Cause

- The sugar level in the wine is higher than the recommended 10%.
- The wine is less than 35°F
- The system is fouled and requires chemical cleaning.

Solution

Try a chemical clean. If this does not sort out the problem, the system may be fouled. Check the 80 micron screen for signs of lees. Clean it out as necessary. If the wine being processed has a high sugar level or is very cold, adjust the pressure relief valve to allow the feed pump to deliver more pressure to the system.



The Feed pump is running, but is not pumping

Cause

Air lock on the inlet line to the feed pump.

Solution

Bleed out the air on the inlet hose to the system as much as possible. If the pump is still not pumping the please call for advice.

Please contact our offices on 707 552- 2616 if any of the above situations occur and can not be resolved by cleaning.